

Telemetric Skin

Mitsuhiro HAKOZAKI*, Hideki OASA and Hiroyuki SHINODA

Department of Electronic & Information Engineering,
Tokyo University of Agriculture & Technology
2-24-16 Koganei, Tokyo 184-8588 Japan

Summary

Human-friendly robots of new generation will require the sensor skin that is soft and covering the whole body. But it would be very difficult to fabricate it with the traditional technology, because placement and wiring of vast amount of sensor elements on the 3-dimensionally configured robot surface is laborious. In this paper we propose a novel method to fabricate such a sensor skin. The skin contains sensor chips which receive the electrical power and transmit the tactile signal without wires. The skin is configured in an arbitrary shape easily, and it is elastic and tough because each sensing element does not need any fragile wires. The principle and the experimental results are described.

Key words: *tactile sensor* , *telemetry* , *artificial skin*

1 INTRODUCTION

Human-friendly robots of new generation will require the sensor skin that is soft and covering the whole body [1]. But it would be very difficult to fabricate such a skin with the traditional technology[2,3,4], because placement and wiring of vast amount of sensor elements on the 3-dimensionally configured robot surface is laborious.

In this paper we propose a novel method to fabricate such a tactile sensor skin based on telemetry. The skin can be configured in an arbitrary shape easily, and

- <1> It is elastic [5], and
- <2> It will be tough because each sensing element does not need any fragile wires to transmit the sensing signal.

The principle and the experimental results are shown.

2 TELEMETRIC SKIN

The goal of the research is to establish a method to fabricate a sensor skin through the following process. (See Fig. 1.)

- <1> Preparation of molding material containing sensor chips which receive the electrical power and transmit the tactile signal without wires.
- <2> Learning the sensor chip position after molding.

In this paper, we design the sensor chip to realize such a process.

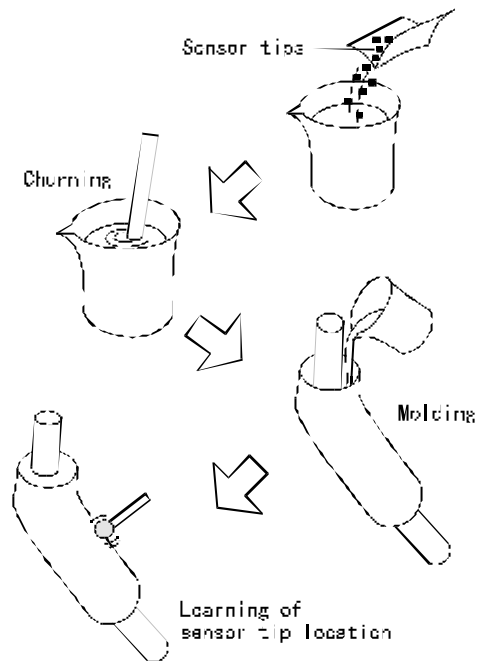

Fig. 1: The process of sensor skin fabrication.

3 STRUCTURE OF THE SENSOR CHIP AND SIGNAL TRANSMISSION

Fig. 2 shows the structure of the sensor chip. Each chip is composed of the three parts, a coil for both sensing and signal transmission, an electrical circuit and a power receiving coil. The simple structure operates as follows.

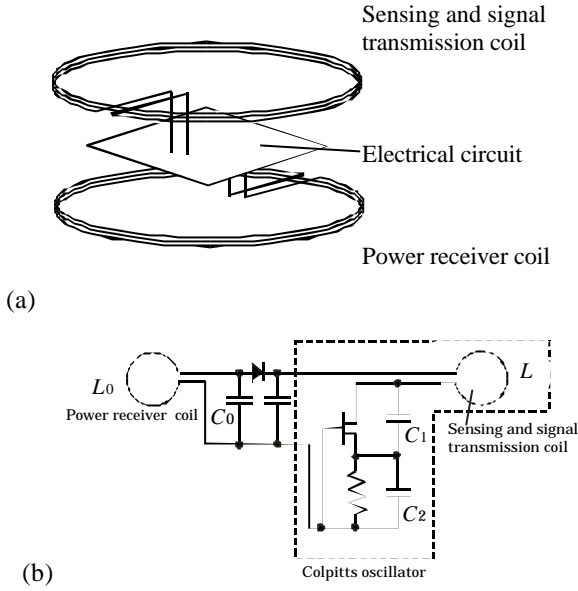

Fig. 2: Structure of the sensor chip. The sensing coil L and capacitance C_1 and C_2 form a Colpitts oscillator.

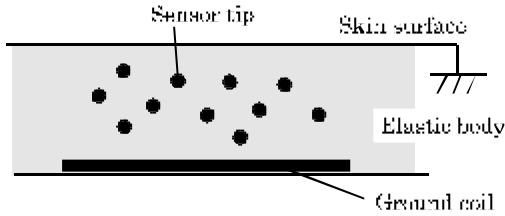

Fig. 3: Powering and signal transmission are done through inductive coupling between the sensor chip and a ground coil. Each chip is identified by both the powering frequency and the signal frequency.

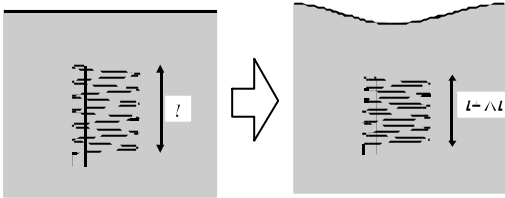

Fig. 4: The principle of tactile sensing. The change of the sensing coil length induces the frequency change of the Colpitts oscillation.

1] Electric power supply

The power supply is done through inductive coupling [6] between chip coil L and the ground coil under the skin. (See Fig. 3.) It is powered only at a resonant frequency

$$\omega_0 = \sqrt{L_0 C_0} \quad (1)$$

which is determined by the L_0 and C_0 in Fig. 2 (b).

2] Sensing and signal transmission

The sensing coil L and capacitance C_1 and C_2 form a Colpitts oscillator with the resonant frequency

$$\omega = \frac{1}{\sqrt{LC}} \quad \left(\frac{1}{C} = \frac{1}{C_1} + \frac{1}{C_2} \right). \quad (2)$$

The oscillation is detected by the ground coil also through inductive coupling. Because the inductance L has the relation with the length of the coil as

$$L = Knpa^2 \frac{N^2}{l}, \quad (3)$$

the normal strain around the coil is detected from the frequency modulation as

$$\frac{d\omega}{\omega} = \frac{dl}{2l}, \quad (4)$$

if Nagaoka's coefficient K is assumed to be constant. (Generally the sensitivity is better than Eq. (4) when the change of Nagaoka's coefficient is considered.)

3] Identification of sensing chip

We identify each sensing chip by two kinds of resonant frequencies. One is the powering frequency ω_0 , and the other is the Colpitts oscillation frequency ω . Therefore if we give N_p and N_s channels to the powering frequency and oscillation frequency, respectively, we can identify large number of elements

$$N_{\text{total}} = N_p \cdot N_s \quad (5)$$

by small number of channels N_p and N_s .

4 DESIGN OF INDUCTIVE POWERING

In this section, we examine the conditions of the coil turn and the frequency for effective powering.

[1] The needs from the circuit chip

Let I be the minimum current of the sensing (and signal transmission) coil L allowed in a certain noise environment. Then the minimum current which must be supplied by a transistor of the oscillation circuit is given as I/Q where Q is the quality factor of the resonance of C_1 , C_2 and L . Therefore the coil must have an ability to give voltage $V \approx 1$ [V], at least, to a load resistance

$$R = QV/I. \quad (6)$$

In this research we assume that $Q \approx 20$, $I \approx 10$ [mA] and $R \approx 1$ [k Ω].

[2] Optimum frequency and turn of the coil

The power receiving coil is equivalent to the circuit on the right hand of Fig. 5 (a). And the power receiver with capacitor C_0 and load resistance R is equivalent to the right hand circuit in Fig. 5 (b), at the resonant frequency $\omega_0 = \sqrt{L_0 C_0}$. Then the voltage V at the load R is written as

$$V = \frac{R}{QZ + R} QE \quad (7)$$

where Q is the quality factor of the resonance and $Z = |\omega_0 L_0|$. Therefore when $QZ \approx R$, the V takes the maximum value

$$V_{\max} \approx \frac{R QE}{2 QZ} = \frac{R}{2} \sqrt{\frac{p}{S_G}} \frac{n_G}{n} l I_G, \quad (8)$$

where n and l are respectively turn of the receiver coil and height of the coil. And n_G , S_G and I_G are respectively turn of the ground coil, area of the ground coil and the ground coil current. This means that

* The maximum load voltage V_{\max} for a fixed load R is depend only on the turn of the receiver coil n which equalizes the QZ with R . Then the smaller the optimum n is, the larger the load voltage V_{\max} .

We measured the equivalent internal impedance QZ vs. turn n and frequency in the experiment shown in **Fig. 6**, for small coils with radius $a = 1$ [mm]. The results are shown in **Fig. 7**. For example, we know that the optimum turn under 1MHz and load resistance $R = 1$ k Ω is about 150 from the figure. And the figure shows that the $QZ \propto n^3$ up to 10 MHz. This means that the V_{\max} will be proportional to the radius of the receiver coil a , if $QZ \propto a^3$ although we have not examined the dependence of QZ on a directly.

Fig. 8 shows that the QZ vs. frequency. In the low frequency range, it is known that $QZ \propto \omega^2$. But over several MHz, we found that the increase of the QZ was saturated. This result tells us that powering over several MHz does not bring higher V_{\max} even if we give the same amplitude of the ground coil current at such a high frequency.

From above discussions we determined the parameters of the powering as

- Diameter of the receiver coil: 2mm,
- Frequency: 1MHz,
- Turn of the coil: 150,

for the load resistance 1 k Ω .

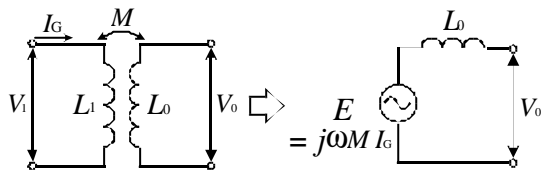

(a)

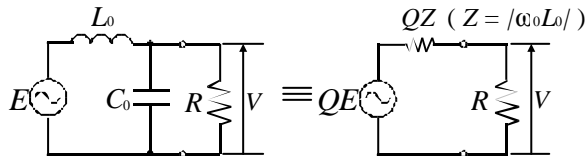

(b)

Fig. 5: (a):Equivalent circuit of power receiving coil. (b): Equivalent circuit of power receiving coil with resonant capacitor (at resonant frequency).

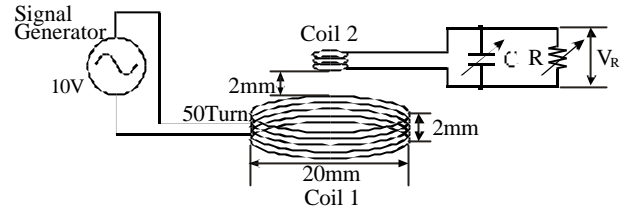

Fig. 6: Experimental setup of inductive powering.

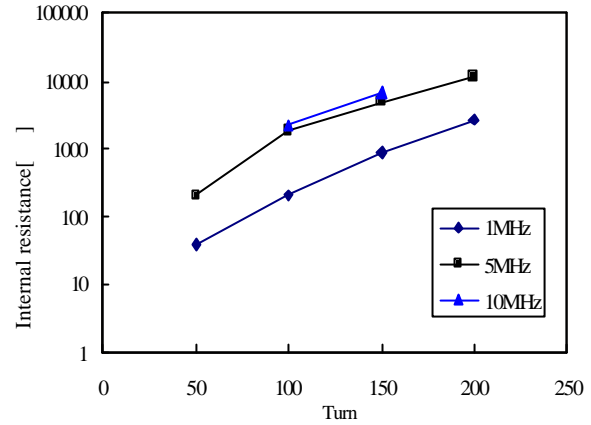

Fig. 7: Equivalent internal resistance vs. turn of coil.

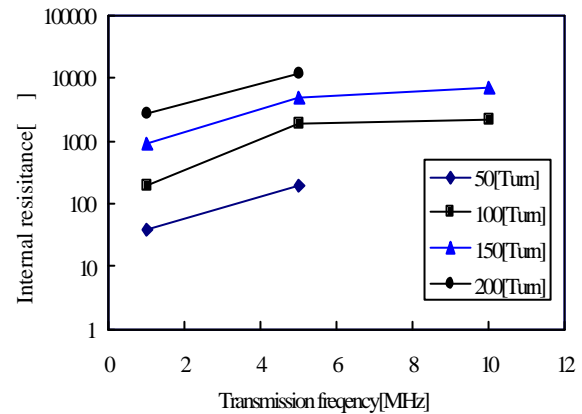

Fig. 8: Equivalent internal resistance vs. frequency.

5 EXPERIMENTS

We fabricated a model of the sensing chip as shown in **Fig. 9**. Because the IC chip has not been completed yet, the circuit composed of discrete elements is located aside the coils. But the powering was done by the chip coil.

The diameter, length and turn of the sensing coil were respectively 2mm, 3mm and 40 turn. And the diameter and the turn of the power receiver coil were respectively 2mm and 150 turn. Both the sensing coil and the power receiving coil were placed in a silicone rubber. (See **Fig. 10**.)

When we supplied the ground coil (20mm in diameter

and 50turn) with 5 [V] amplitude of 1 [MHz] through impedance matching capacitor, we observed oscillation of 8.1 [MHz] under the following conditions:

C_1 : 270 [pF], C_2 : 2200 [pF],
 g_m of the FET(2SK363) = 60 [mS]. (See Fig. 2 (b).)

Then the frequency was shifted as shown in Fig. 11 while we pressed an object (an acrylic cylinder 2mm in diameter) on the rubber surface.

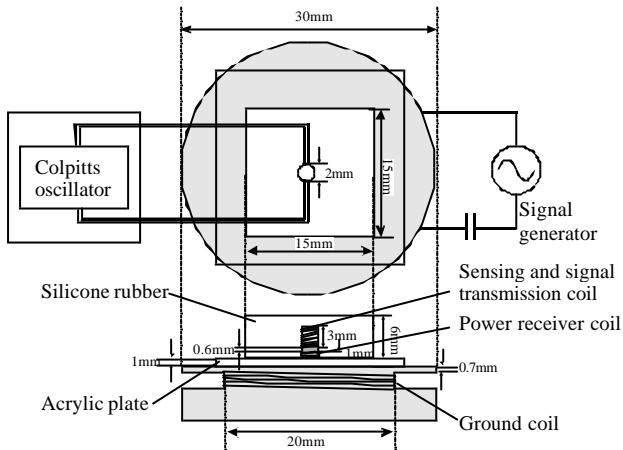

Fig. 9: Experimental setup of telemetric tactile sensing. Because the IC chip has not been completed yet, the circuit composed of discrete elements is located aside the chip coils.



Fig. 10: Sensing and powering coils in silicon rubber.

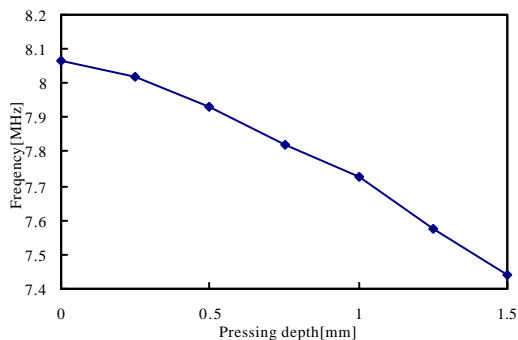

Fig. 11: Oscillating frequency vs. pressing depth.

6 USE OF MULTI-CHIP SERVICE

The IC chip fabrication is now in the process of the project MCS01 by the MMCS committee. We have confirmed the operation of the bi-polar transistor circuit shown in Fig. 12 by PSPICE using the parameters offered by MCS01, considering the equivalent internal resistance. The oscillating frequency of the circuit is 27MHz.

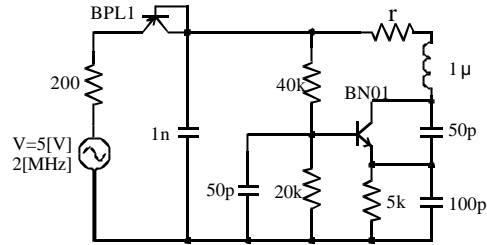

Fig. 12: PSPICE simulation of the IC chip circuit.

Acknowledgment

The research was partly supported by JSPS-RFTF 96P00801, the Japan Society for the Promotion of Science.

References

- [1] M. Inaba, T. Ninomiya, Y. Hoshino, K. Nagasaka, S. Kagami and H. Inoue, "A Remote-Brained Full-Body Humanoid with Multisensor Imaging System of Binocular Viewer, Ears, Wrist Force and Tactile Sensor Suit," Proc. 1997 IEEE Int. Conf. Robotics and Automation, pp.2497-2502, 1997.
- [2] H. R. Nicholls and M. H. Lee, "A Survey of Robot Tactile sensing Technology," Int. J. Robotics Res., Vol. 8, No.3, pp.3-30, 1989.
- [3] P. P .L. Regtien, "Tactile Imaging," Sensors and Actuators A, Vol. 31, pp.83-39, 1992.
- [4] R. D. Howe, "Tactile Sensing and Control of Robotic Manipulation," Journal of Advanced Robotics, Vol. 8, No. 3, pp.245-261, 1994.
- [5] H. Shinoda, K. Matsumoto and S. Ando, "Acoustic Resonant Tensor Cell for Tactile Sensing," Proc. 1997 IEEE Int. Conf. Robotics and Automation, pp. 3087-3092, 1997.
- [6] J. A. V. Arx and K. Najafi, "On-Chip Coils with Integrated Cores for Remote Inductive Powering of Integrated Microsystems," Proc. TRANSDUCERS '97, pp. 999-1002, 1997.