

Cell-Bridge-Based Connection of High Density Sensor Elements

Akimasa Okada*, Yasutoshi Makino*, and Hiroyuki Shinoda*

In this paper, we propose a novel network system named “cell bridge system” for a high-density flexible sensor and actuator array. The cell bridge system consists of two elements, a “cell bridge” and a “cell”. The cell bridge is a signal transmission device by a LSI chip based on 0.35um CMOS process. The cell is a two-dimensional conductive area where the signal is transmitted. The proposed system is constructed by connecting the cell bridge at the boundary between a pair of cells with two electrical contacts. The cell bridges combine the cells into an array without long wires. As the preliminary step, we developed prototype cell bridges and fabricated a stretchable network sheet to examine the communication function of the proposed system. The experimental results showed the proposed system was capable of high-speed communication. We also proposed a flexible speaker array using cell bridge system and fabricated a flexible speaker element for it.

Keywords : sensor array, network sensing, cell bridge, two-dimensional communication, wireless, wearable computing

1. Introduction

We often need a flexible array of sensors and actuators for a pressure detectable sensor sheet on a car sheet or for a robot skin. One of the problems in manufacturing such arrays is that how we construct the high-density network physically among sensors and actuators. If we fabricate these applications with wires, the flexibility will be lost because of hardness of many wires. Radio technology [1] is used as a solution for that problem. But while the flexibility can be kept, it will cause the interference among nodes which lowers the acquired throughput, and waste the power for communication.

In this paper, we propose a novel network system named “cell bridge system” for high-density sensor networks. Fig.1 shows the concept of the cell bridge system. There are two important elements, a “cell bridge” and a “cell” in it. They are a signal transmission element and a two-dimensional conductive area, respectively. The proposed system is constructed by connecting the cell bridge at the boundary between a pair of cells with two electrical contacts. A cell bridge transmits signals through the cell to other cell bridges, successively. The multi-hopping sends data packets to a remote node without long wire. During the signal transmission, the generated electric field is localized in the sheet.

The cell bridge system is more effective when we give the cell the ability of the sensing or actuator function. The cell can function as not only the communication medium but also the sensing node. In [2], the cell is given the function of the electrostatic pressure sensor.

As a related work that aims a similar goal, “Two-Dimensional Signal Transmission”[3] is studied. This technology realizes the flexible communication sheet with no wiring by localizing RF signals in the sheet. However, if we use segmented conductive sites for sensing or other purposes, the cell bridge system can be simpler than the two-dimensional signal transmission system with additionally attached sensors. Another example is “Thinking Car-

pet [4]” invented by Infineon. Devices with communication function are mounted in the sheet. In this system, however, the connections among devices are realized with many wires.

This paper is organized as follows. In Section 2, we explain the functions and architectures of the cell bridge system. In Section 3, we show the prototype cell bridge system and experimental results. We developed a stretchable sheet with prototype cell bridges to evaluate the communication function. In section 4, we present an application of cell bridge system. We propose a flexible speaker array using cell bridge system, and fabricate an electrostatic speaker element for it.

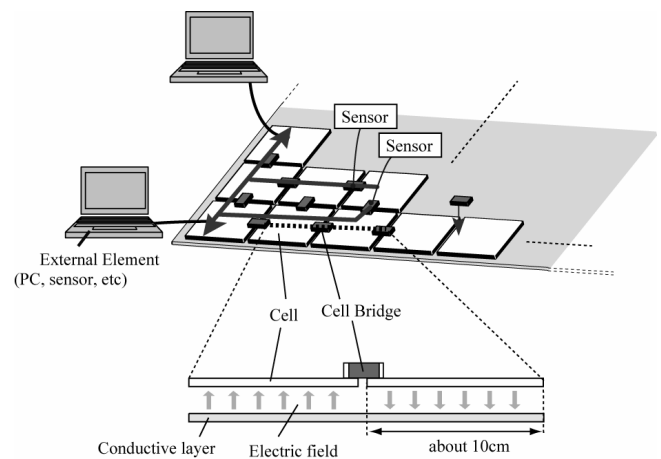

Fig. 1 the concept of the cell bridge system.

2. Principle

In this section, we explain the principle of the cell bridge system. First we show the topology. Then we present the principle and the property of the signal transmission. Finally we explain the protocol.

2.1 Topology The cell bridge system consists of four elements, a cell, a cell bridge, an inductor chip and a ground layer.

* Department of Information Physics and Computing, Graduate School of Information Physics and Technology, the University of Tokyo, 7-3-1 Hongo, Bunkyo-ku, Tokyo, Japan 113-8656

The diagram of the proposed system is shown in Fig.2. The cell is a two-dimensional conductive area. We can use various materials for the cells if they have sufficiently low conductivity to provide the electrical energy to the cell bridges. The half of all the cells are connected to a positive voltage terminal through the inductor chips and the other half are connected to the negative one. We call them “positive cell” and “negative cell” respectively.

The cell bridge is a signal transmission element. It is put at the boundary between the positive cell and the negative cell. The voltage between them drives the cell bridge. In the case of the topology of Fig. 2, the signal path of the system is shown in Fig.3.

Inductor chips maintain the voltage of the positive cell and the negative cell in DC. At the operating frequency of the cell bridge, the inductor chips function as insulators. Therefore they don't affect the signal transmission in the system.

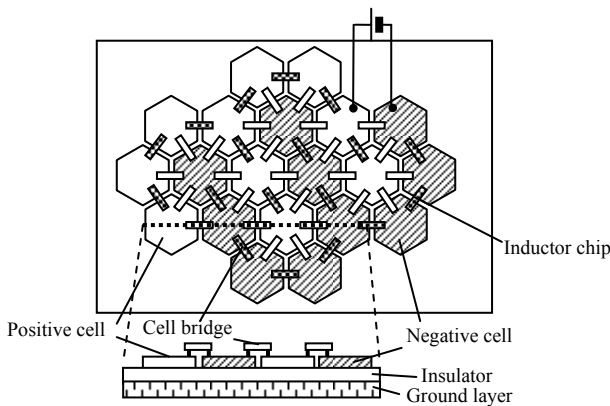

Fig. 2 the diagram of the cell bridge system. Top view of the cell bridge system(upper). Cross-section of the system(lower).

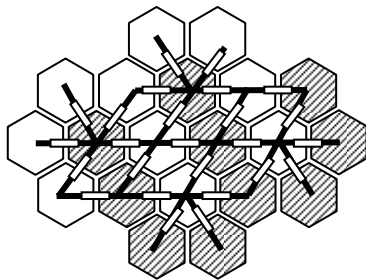

Fig. 3 The signal paths of the system in Fig.2. The lines represent the signal path. The inductor chips are not described.

2.2 Signal Transmission In this section, we explain how the cell bridge transmits and receives signals among adjacent cell bridges.

Fig.4 (a) shows the cross-section of the proposed system and Fig.4 (b) shows the equivalent circuit of Fig.4 (a). In the following of this section, we assume the center cell bridge in Fig.4(a) transmits signals.

When the cell bridge transmits signals, it applies the voltage $V(t)$ between the cells the cell bridge connects with. In this case, they are cell 2 and cell 3. The neighbor cell bridges can receive signals by comparing the voltage between the cells they are connected with. The voltage of cells beyond the neighbor cell bridges (cell 1 and cell 4) doesn't change because of the following reason.

The cell bridge functions as a resistor R when it doesn't transmit

signals as shown in Fig.4 (b). And we assume the capacitance between the cell and the ground layer is written as C . Then if the angular frequency ω of the signal satisfies

$$\frac{1}{C \cdot \omega} \ll R, \dots \dots \dots (1)$$

the voltages generated at cell 2 and 3 are $-V(t)/2$ and $V(t)/2$, respectively, while the voltage changes at cell 1 and 4 are as small as $|V(t)| (1/C\omega)/R$.

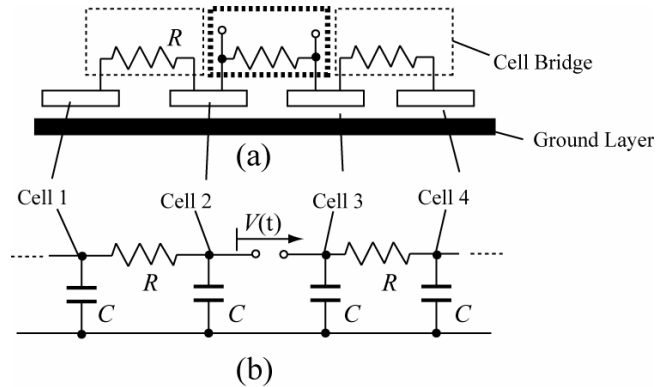

Fig. 4 the cross-section of the cell bridge system(upper). The equivalent circuit of the cross-section(lower)

2.3 Protocol In this section, we describe the protocol outline of the cell bridge system. In the current system, we implemented the function of the random communication with which cell bridges can transmit signals to an arbitrary destination.

The following properties make the protocol simpler compared with the problem in the ordinary wireless ad-hoc networking.

- (1). the relative positions among the cell bridges don't change.
- (2). the boundary of the signal transmission coverage is clearly defined.
- (3). the number of the peripheral cell bridges is as small as 6 at most.

The cell bridge is allowed to have an extremely limited resource of memory. In our design, a cell bridge has a memory space of only one packet to save the circuit area.

3. Experiments and Results

We developed prototype LSI chips to examine the communication function. Fig. 5 (a) shows the expanded photo of the developed LSI chip based on 0.35um CMOS process. Fig. 5 (b) shows a cell bridge with the LSI chip. The size of the LSI chip with analog-digital mixed circuits is about 5 mm by 5mm. The size of the digital circuit core is about 1.1mm by 1.1mm. The operating frequency of the LSI chip is designed to be 50MHz. This LSI has the minimal function necessary for signal transmission and routing. In the current protocol, we tolerate 10 % of the clock-frequency difference between a transmitter and a receiver. The difference is compensated by signal sampling of 16 phases in one clock period. Then the chip requires no clock standard outside of the CMOS circuit. Fig.6 shows the waveform of the clock oscillation by the cell bridge. The average frequency is 55.6MHz

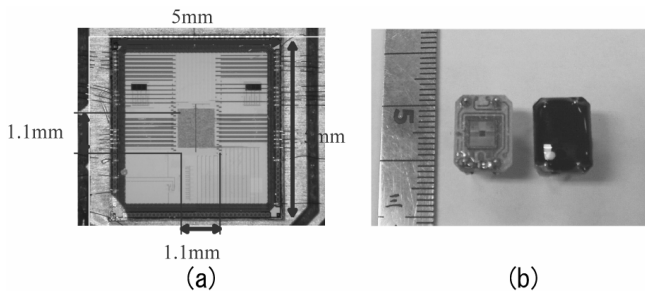

Fig. 5 (a): The photo of the prototype LSI., (b): the cell bridge with the LSI

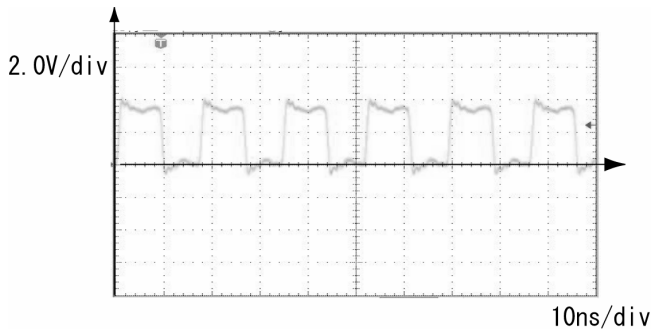

Fig. 6 The waveform of the clock oscillation. The average frequency is 55.6MHz

The network sheet with the prototype cell bridges is shown in Fig. 7. The materials of cells and insulators are stretchable fabrics. The thickness and the sheet resistance of the cell are 225 μm and 3.0 ohm, respectively. The size of cells is 13 cm by 13cm. Two cell bridges are mounted at the boundary between a pair of cells.

The cross-section of the network system constructed with the prototype cell bridges are shown in Fig. 8. The laminar structure of the system consists of cells, a ground layer and a power layer. The prototype cell bridge is supplied with the power by contacting the ground layer and the power layer. In the current stage, the structure is not faithful to the design goal as shown in Fig. 2, in which the cell bridge has only two electrical contacts on a single layer of the sheet.

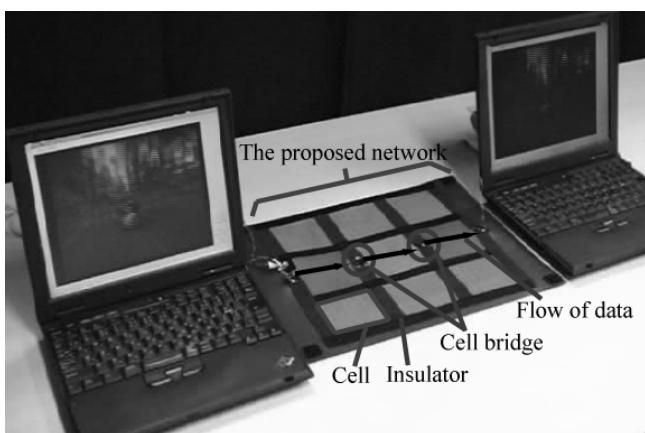

Fig. 7 The prototype cell bridge system with two prototype cell bridges

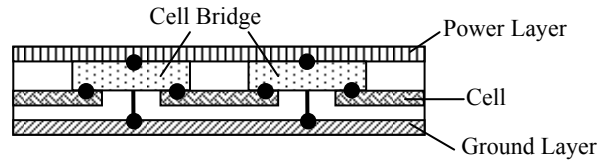

Fig. 8 the cross-section of the cell bridge system in Fig.7

The specifications of the experimental conditions and results are showed in Table1. In the experiment, image data from one PC is transferred to the other. The packet size is 245 bit and the data size per a packet is 116bit. The delay time between PCs is 8.81 μs . Bit error rate is less than 0.0003 % and disappearance rate of packets is about 0.00025 %. The power consumption is 247.5mW in waiting state and 330mW in communication state. In the current stage, the signal amplitude is unnecessarily large compared with the environmental noise amplitude. Minimizing the power consumption is a future work. The results show the system is capable of high-speed and high-quality communication.

Table. 1 the specification of the cell bridge and the experimental results

Specification of cell bridge	
Operating frequency	55.6 MHz
Instant throughput F	55.6 Mbps
Condition of measurement	
Transmitted data size	16,692,868byte
Packet size B	245 bit
Data size per a packet	116 bit
The number of transmitted packets	1,192,348
The number of hopping N	2
Results (average)	
Total transmission time T	60.5s
Throughput between nodes	2,152 kbps
Delay time NB/F	8.81 μs
Bit Error rate	Less than 0.0003 %
Packet loss rate	0.00025 %
Power consumption	247.5mW(waiting) 330mW(in communication)

4. Application

We are developing a flexible speaker array using cell bridge system. We report the fabrication of a flexible electrostatic speaker for it.

Fig. 9 shows the principle of the electrostatic speaker. The diaphragm vibrates by the electrostatic force F between a pair of electrodes given as

$$F = \frac{\epsilon_0 \epsilon S (E + e)^2}{2(d - x_0 - x)^2} \dots \dots \dots (2)$$

where

- ϵ_0 the permittivity of vacuum;
- ϵ dielectric constant;
- S the area of the electrode;
- E the voltage of DC power source;
- e the signal voltage;
- d the initial distance between the two electrodes;
- x_0 the displacement of the electrode by the DC power source;

x the displacement of the electrode by the signal voltage.

The DC power source is necessary for the linear response to the input signal. Fig.10 shows the cross-section of the fabricated flexible electrostatic speaker. A piece of conductive fabric and a piece of conductive paper sandwich a 4 μm polyimide film. The size of the piece is 18cm by 18cm. The total thickness is about 314 μm . The conductive paper and the polyimide are bonded partly to allow vibration.

We measured the frequency response of the fabricated speaker with the experimental setup shown in Fig. 11. One side of the speaker is fixed to the board and the opposite side is free. The distance between the condenser microphone and the speaker is less than 1 mm. An input signal is a sine wave at 20 Vpp, while E is 100V. In Fig. 12, we show the observed sound pressure p in decibel L_p calculated as

$$L_p = 20 \log_{10} \frac{P}{p_0}, \dots\dots\dots(3)$$

where $p_0 = 2 \times 10^{-5}$ (Pa). The characteristics in the frequency range higher than 1kHz is flat.

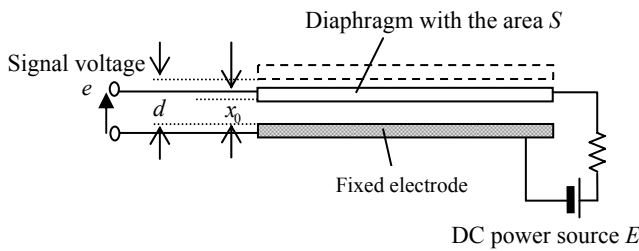

Fig. 9 The principle of the electrostatic speaker

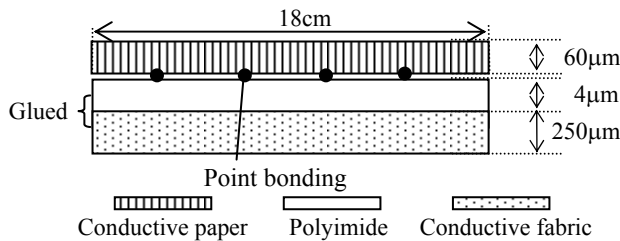

Fig. 10 The cross-section of the fabricated electrostatic speaker

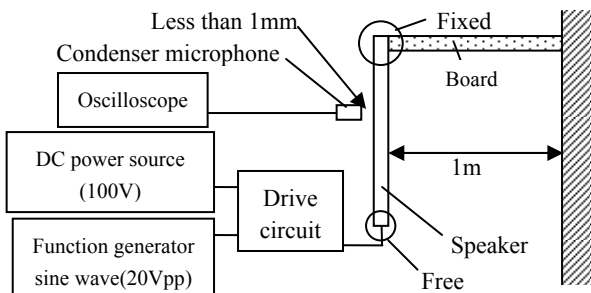

Fig. 11 The side view of the experimental setup

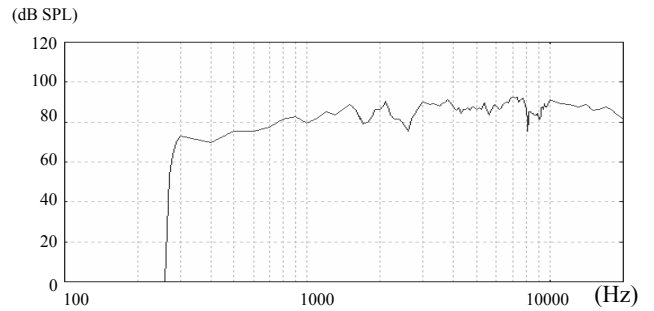

Fig. 12 The frequency response of the fabricated electrostatic speaker

5. Summary

In this paper, we proposed “cell bridge system” for sensor and actuator arrays without long wires. The proposed system is constructed by combining multiple two-dimensional areas called “cells” with the signal transmission element called “cell bridges”.

We described the detail of the cell bridge system and developed the prototype cell bridge based on CMOS technology. And we fabricated the stretchable network sheet with cell bridges. The experimental results showed the proposed system is capable of high-speed and high-quality signal transmission.

We also showed the flexible electrostatic speaker as an example of the actuator array element. The speaker was fabricated with conductive fabric and conductive paper. Combining the speaker elements into an array is the future work.

Acknowledgement

We thank Naoya Asamura, Tachio Yuasa, Mitsuhiro Hakozaki, Xinyu Wang, and Hiroto Itai, Cellcross Co., Ltd. for their cooperation on fabricating and evaluating the prototype, and providing ideas on device structures and their applications.

References

- (1) Andrew S. Tanenbaum : “Computer Networks Fourth Edition”, Person Education International, (2003)
- (2) T.Hoshi, and H.Shinoda : “Tactile Sensing Using Nonlinear Elasticity”, Proc. Sice Annual Conference, pp.2978-2981, Okayama (2005)
- (3) K.Minamizawa, Y.Makino, and H.Shinoda, “Two-Dimensional Signal Transmission for Networked Sensing”, Proc. Sice Annual Conference, pp.3816-3819, Okayama (2005)
- (4) Infineon, <http://www.infineon.com/>